

# SmartLog Pro™ with Turnstile Installation, Operation and Maintenance

Made in the  
United States of America and Britain

Figure 1. EMIT 50789 SmartLog Pro™ with Turnstile

## Description

The EMIT SmartLog Pro™ with [EDS EDSUKTHH28 Half Height Turnstile](#) verifies the functionality of an operator's wrist strap and footwear, logs the test results, and controls access to an ESD Protected Area. The turnstile unlocks after the operator's wrist strap and/or footwear is determined to act as a path-to-ground. All operator test activity is logged into a database to meet the EN 61340-5-1 Compliance Verification and record keeping requirements. Each log entry includes operator identification, test results, resistance measurements, time, temperature and humidity.

See [TB-6594](#) for more information on the patented\* EMIT SmartLog Pro™.

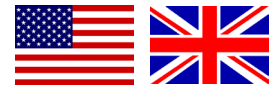
The [EDS EDSUKTHH28 Half Height Turnstile](#) is a bidirectional tripod swing turnstile. Both its cabinet and tripod rotors are composed of stainless steel. LED passage signs are located at both the entry and exit sides. A flashing green arrow indicates when to pass, and a red X indicates when the turnstile is closed.

The turnstile is configured to Fail-Safe Loss-of-Power Operation. Should loss of power occur, the turnstile's arms will unlock and rotate freely in both directions to allow operators to pass through.

The EMIT 50789 SmartLog Pro™ with Turnstile has an input voltage rating of 220 VAC.

"A compliance verification plan shall be established to ensure the organization's fulfilment of the requirements of the plan. ... Compliance verification records shall be established and maintained to provide evidence of conformity to the technical requirements. The test equipment selected shall be capable of making the measurements defined in the compliance verification plan." (EN 61340-5-1:2016 clause 5.2.4 Compliance verification plan)

"Wrist straps should be tested periodically. The frequency of testing, however, is driven by the amount of usage, wear and ESD risk exposure that can occur between tests. For, example, what is the quantity of product handled between test periods? Typical test programs recommend that wrist straps that are used daily should be tested daily. However, if the products that are being produced are of such value that a guarantee of a continuous, reliable ground is needed then continuous monitoring should be considered or even required." (CLC/TR 61340-5-2 User guide Wrist Strap clause 4.7.2.4.4 Test frequency)

Footwear Test method "The operator shall stand with one foot on the conductive footwear electrode. The hand contact plate shall be pressed to verify that the person/footwear system resistance is within acceptable parameters (see Figure A.1). The test shall be repeated for the other foot. The test apparatus can be an integrated, commercially available tester or other instrumentation that is capable of measuring resistance from  $5,0 \times 10^4$  ohms to at least  $1,0 \times 10^9$  ohms. The tester open-circuit voltage is typically between 9 V d.c. and 100 V d.c." (EN 61340-5-1:2016 Annex A Footwear test method)

Note: SmartLog Pro™ provides wrist strap test per IEC 61340-4-6 wrist strap continuity test with upper limit  $< 3,5 \times 10^7$  ohms, and footwear testing per IEC 61340-5-1 Annex A with upper limit  $< 1,0 \times 10^8$  ohms.

## Packaging

- 1 SmartLog Pro™ with Turnstile
- 1 Wall Mounting Bracket
- 1 Dual Independent Foot Plate
- 1 Allen Wrench, 5/32"
- 4 M10 x 85 Steel Anchors
- 4 M10 x 20 Inbus Bolts
- 4 M10 Washers
- 2 Turnstile Keys
- 1 Certificate of Calibration

\*US Patents 6,078,875 and 6,809,522

EMIT - 3651 Walnut Avenue, Chino, CA 91710 • (909) 664-9980 • Website: [DescoEMIT.com](#)

## Installation

### Installing the Turnstile

220 VAC and Ethernet access are needed at the location of every SmartLog Pro™ with Turnstile prior to installation.

[Click here](#) to download the EDS EDSUKTHH28 Turnstile Operation Manual and see instructions on anchoring and wiring the turnstile. Use the included anchors, bolts and washers when anchoring the turnstile to the ground.

### Setting up the SmartLog Pro™

See [TB-6594](#) to learn more about the features and components of the SmartLog Pro™.

1. Open the turnstile's lid using the included keys.
2. Connect the Ethernet cable to the back of the SmartLog Pro™.
3. Locate the power switch inside the turnstile cabinet, and set it to ON.
4. Locate the power switch on the back of the SmartLog Pro™, and set it to ON.
5. Locate the foot plate cable at the base of the turnstile and connect it to the Dual Independent Foot Plate, so operators can place their feet on it while performing tests at the turnstile's entrance.
6. Complete the installation by establishing communication to the SmartLog Pro™ via the Ethernet cable. See the "Network Setup" procedure in [TB-6594](#) for more information.



Figure 2. Installing the Dual Independent Foot Plate

## Operation

NOTE: The SmartLog Pro™ must first be programmed with the user ID table using the TEAM5 Software before being deployed for employee use, or the default test settings will be applied.

See the [TEAM5 User Manual](#) for more information.

If the SmartLog Pro™ is located near a restroom, sink or other water source, operators will need to be instructed to thoroughly dry their hands before testing. Wet hands may cause inaccurate test results and damage to the tester.

1. A circling light around the test switch indicates when the SmartLog Pro™ is on standby and ready to perform a test.
2. Initiate the test procedure by identifying yourself to the SmartLog Pro™. This may be done using the touchscreen keypad, barcode scanner or proximity reader.

NOTE: Hold the proximity badge in front of the RFID icon for a full second if using proximity badges. See Figure 4.



Figure 3. Using the barcode scanner



Figure 4. Holding a proximity badge in front of the RFID icon on the SmartLog Pro™

3. Follow the prompt on the SmartLog's display.
4. When performing a footwear test, be sure to place both feet on the dual foot plate (one foot per plate).

NOTE: Keep the foot plate clean with 99% isopropyl alcohol when using the 1 Gigohm high test limit. A dirty foot plate could yield a false pass.

When performing a wrist strap\* test, be sure to completely plug in the wrist cord into the tester's jack.



Figure 5. Performing a footwear and wrist strap test

5. To begin the test, use your finger to bridge the test switch's inner and outer contacts. The blue standby LED will become solid to indicate that the test has been initiated. Hold your finger down until the test results are displayed on the touchscreen.

If your finger is removed too early, the tester's blue LEDs will blink three times to indicate that the test was not completed. DO NOT touch any metal other than the SmartLog Pro™ or the turnstile while performing your test as this will affect your results.





Figure 6. Performing a single-wire wrist strap test

- The relay terminal will activate and unlock the turnstile if the defined tests are passed.

NOTE: Failures may be caused by dry skin or minimal sweat layer. For wrist straps, try using an approved dissipative hand lotion such as Reztore™ ESD Hand Lotion prior to use. Footwear test results can be improved by taking a short walk to build a sweat layer for better conductivity.

- Pass through the turnstile. The turnstile will re-lock after one rotation.

NOTE: The turnstile will remain unlocked until either the operator passes through or 15 seconds expire.

\*The SmartLog Pro™ may also be used to test smocks or garments that feature a grounding mechanism for operators using a coiled cord connection.

## Calibration

Frequency of recalibration should be based on the critical nature of those ESD sensitive items handled and the risk of failure for the ESD protective equipment and materials. In general, EMIT recommends that calibration be performed annually.

Use the EMIT 50424 Limit Comparator and EMIT 50784 5-Pound Electrode to perform periodic verification (once every 6-12 months) of the SmartLog Pro™. The Limit Comparator can be used to check the test limits of the SmartLog Pro™ without removing it from the turnstile or factory floor.

See [TB-6581](#) for more information.



Figure 7. EMIT 50424 Limit Comparator



Figure 8. EMIT 50784 5-Pound Electrode for Limit Comparator

## Specifications

### SmartLog Pro™ with Turnstile

SmartLog Pro™ AC/DC Power Adapter  
 Input Voltage and Frequency (External Adapter) Power Input: 100-240VAC, 50/60 Hz  
 Power Output: 5VDC, 3.0A  
 Cable Length: 5 ft. (1.5 m)

Turnstile Input Voltage and Frequency 220VAC, 50/60 Hz

Operating Temperature 70°F to 85°F (21°C to 30°C) for 1 gigohm test limit  
 41°F to 85°F (5°C to 30°C) for all other test limits

Environmental Requirements Indoor use only at altitudes less than 6500 ft. (2 km)  
 Maximum relative humidity of 80% up to 85°F (30°C) decreasing linearly to 50% @ 85°F (30°C)  
 Maximum relative humidity of 50% at 1 gigohm setting

Dimensions (Crated) 47" x 31" x 54" (119 cm x 78 cm x 137 cm)

Dimensions (Uncrated) See Figure 9

Weight (Crated) 257 lbs (116 kg)

Weight (Uncrated) 135 lbs (61 kg)

Test Accuracy ±20% for 1 gigohm footwear test limit  
 ±10% for all other test limits

Test Switch Voltage 5 VDC @ open circuit

Wrist Strap and Footwear Test Voltage 30 VDC @ open circuit  
 Test current is limited by resistors and varies on the test range setting (100 kilohms - 1 gigohm)

### Dual Independent Foot Plate

Dimensions 14.0" x 16.0" x 0.9" (35.6 cm x 40.1 cm x 2.3 cm)

Weight 7.5 lbs (3.4 kg)

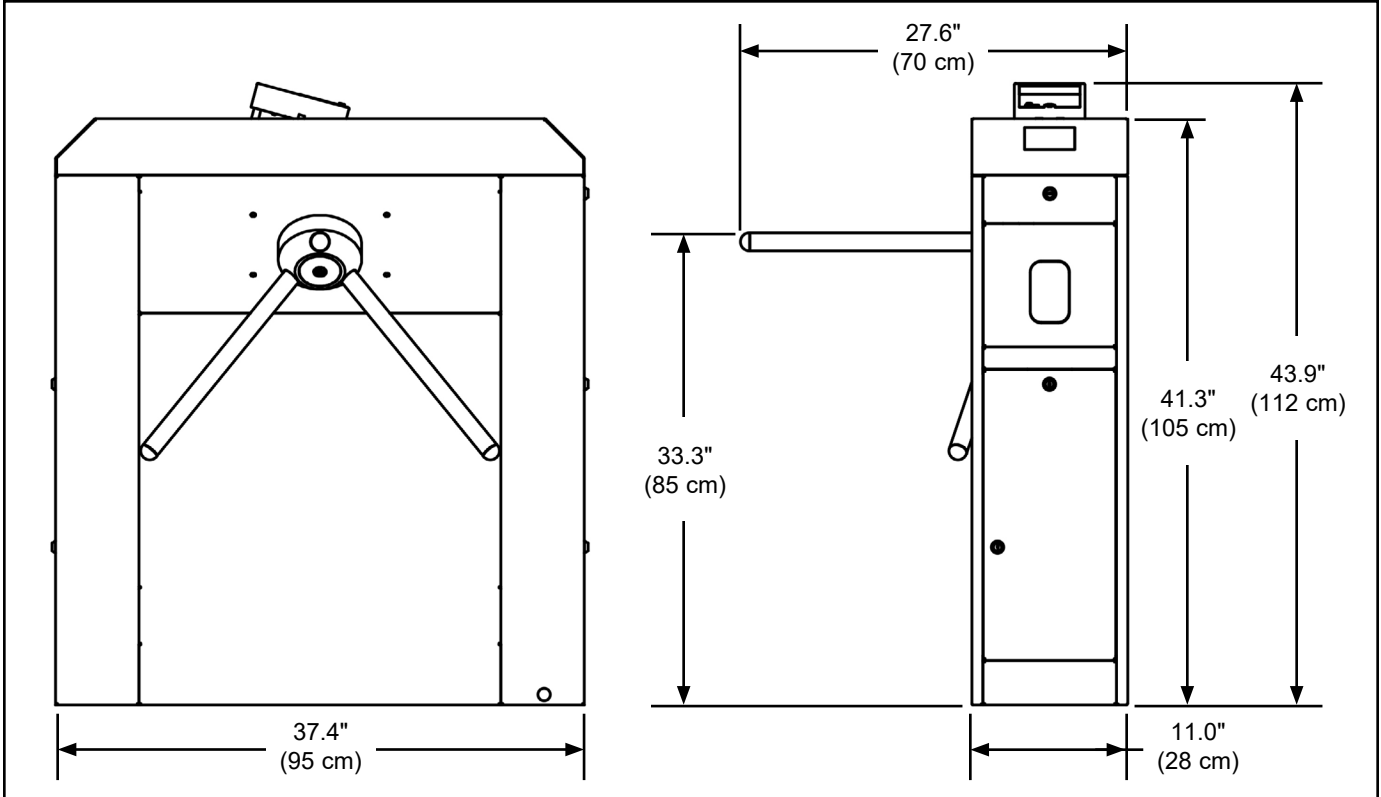

Figure 9. Dimensions of the EMIT SmartLog Pro™ with Turnstile

**Limited Warranty, Warranty Exclusions, Limit of Liability and RMA Request Instructions**

See the EMIT Warranty -

<http://emit.descoindustries.com/Limited-Warranty.aspx>